

Development and Research of the Stamp for Cutting of a Rolled Stock With a Differentiated Clamp

Sergii G. Karnaukh

Assistant professor
Basics of Designing a Machine
Donbass State Engineering Academy
Ukraine

Oleg E. Markov

Professor
Computerized Design and
Modeling of Processes and Machines
Donbass State Engineering Academy
Ukraine

Alexander A. Shapoval

Assistant professor
Department of Manufacturing Engineering
Kremenchuk Mykhailo Ostohradskyi
National University
Ukraine

Kateryna V. Zubenko

Assistant professor
Donbass State Engineering Academy
Ukraine

The work aims to develop and research a stamp with a differentiated clamp of a rolled stock for cutting by shear. A new stamp design with a differentiated clamp of the rolled stock has been developed. In terms of their technical and economic indicators, these stamps meet or exceed the modern samples of similar punch tools. At the same time, in the process of vertical cutting, a constant position of the rolled stock axis is ensured. The transmission of force to the clamp through the rolled stock is excluded. The stamp design ensures its sufficiently high rigidity and relatively small overall dimensions. Based on the analysis of the mathematical model of a stamp with a differentiated clamp, the effective angles of force transmission to the clamp and the cutting of the rolled stock between the stamp parts have been established. The resulting model was used to optimize the angles of force transfer to the clamp, and the cutting rolled stock, respecting the force from the side of a buffer and the minimum required press force. At the same time, the vertical stroke of the moving parts is reduced, the overall dimensions of the stamp are decreased, and the buffer also has a minimum size. To reduce the required force of the press, it is necessary to reduce the value of a frictional slipping coefficient by using antifriction materials on contact surfaces and ensuring good lubrication conditions. The results of the conducted experiments confirm the adequacy of the mathematical model. The value of the required force on the press slide available from experiments is slightly higher than the values obtained by the developed analytical model. The results of the stamp implementation show that: the stamps are efficient and reliable in exploitation; the quality of the cutoff workpieces corresponds to the quality indicators of the workpieces cut on similar modern equipment.

Keywords: cutting by shear, differentiated clamp, stamp, wedge, rolled stock, workpiece, quality.

1. INTRODUCTION

Mechanical engineering plays a leading role in social and economic development and is considered a foundation of the industry [1-6]. The efficiency makes a great contribution to the finished cost of engineering products of workpieces production [1, 2]. The cutting of rolled stock into cut-to-length is the most demanded operation in the engineering industry since the result of this operation is the production of workpieces, both for further metal forming and cutting [3-5]. The quality of workpiece faces influences the precision and surface quality of forged pieces [1]. Therefore, the need to increase the efficiency of the shearing operations is obvious since it directly affects the cost of the finished product. [6-10].

In production, more than ten methods of cutting rolled stock into cut-to-length are used. The most perspective is waste-free methods for cutting the rolled

stock. Waste-free methods include cutting by a shear method, which is highly productive and economical [1, 3-5].

Considering that millions of workpieces are produced every year, the task of improving techniques and equipment used in rolled stock production is actually. This explains the scientists' and industrialists' interest in improving the cutting method with a shear [1-5, 10]. Comprehensive studies of the waste-free methods for cutting rolled stock were widely carried out by many scientists in England, Germany, Japan, Ukraine, etc. [1-2, 5, 11]. During this time, a large amount of information about the nature, mechanisms, and failure criteria was accumulated.

One of the main problems of equipment used for cutting processes is its work under conditions of a sudden drop in load. This effect leads to the press frame destruction and lay-up of the foundation and is accompanied by hydraulic impact initiation in the hydraulic system of the press, which is connected with cavitation [3-6]. It leads to choosing high-power equipment.

Of the known schemes for cutting rolled stock by shear with an active cross-clamp, the most advanced is a scheme of cutting with a «differentiated clamp». The fundamental difference between such cutoff schemes is

Received: August 2021, Accepted: September 2022

Correspondence to: Prof. Oleg E. Markov,
Donbass State Engineering Academy,
Akademichna Str., 72, Kramatorsk, Ukraine, 84313.

E-mail: oleg.markov.ond@gmail.com

doi: 10.5937/fme2204674K

© Faculty of Mechanical Engineering, Belgrade. All rights reserved

FME Transactions (2022) 50, 674-682 674

that the clamping power of the rolled stock in knives is variable by value and changes proportionately with the cutting force. At the moment of shearing cracks formation, the cutting force decreases to a minimum, and, therefore, the cross-clamp force decreases proportionately with it. The workpiece gets the opportunity to move in the axial direction from the rolled stock, excluding defect formation at workpiece faces [1, 2].

Mathematical models for selecting rolled stocks were developed in work [3]. New technologies for the manufacture of the workpiece by cutting with stamps were proposed in the [4]. The main directions of process improvements to obtain the geometric accuracy of the workpieces are considered in the works [1, 5-6]. The main directions of scientific research [12-16] were: the creation favorable of metal stress state in the cutting zone and; the development of new designs of stamp and cutting tools.

Thus, the equipment and punch tools, where a differentiated clamp of rolled stock is implemented, provide a higher quality of cut workpieces. At the same time, there is a certain disproportion between the theoretical advances in the technology of cutting the rolled stock with a differentiated clamp and the improvement of equipment for its implementation. The disadvantages of design studies cause this. First of all, because of the excessive overall dimensions of the stamps, it is necessary to choose the press not according to the required force, but according to the dimensions of the stamp space. Also, the low rigidity of stamp construction is a disadvantage [1, 2].

The mathematical modeling of multi-parameter destruction processes differs from real processes. To simulate the processes of separating rolled stock into dimensional workpieces various CAE systems are used; they are based on the finite element method: ANSYS [17], LS-DYNA [18], DEFORM 3D [19], QFORM [20]. The obtained results of finite element analysis allow the researcher to understand the main trends of the separation process and to obtain fairly accurate quantitative data concerning the distribution of temperature-velocity fields and tensor's components of stress-strain state [21-25].

The work aims to develop and research stamps with a differentiated clamp for cutting rolled stock by shear.

2. DESIGN OF THE STAMP WITH A DIFFERENTIATED CLAMP

Stamp designs with a differentiated clamp are developed, investigated, and introduced into production for cutting rolled products with a diameter of 50 mm.

Based on the analysis of the reported and patent searches, a punch tools scheme with a differentiated clamp on both sides of the cutting plane was chosen; wedge mechanisms for clamping and cutting the rolled stock were used in the stamp design as having a higher rigidity. The basic design of the proposed stamp has been presented in Figure 1 [26].

The stamp consists of a body made in the form of two support (1, 2) and two crosses (3, 4) plates, connected using pins 5, two pairs of mutually and by pairs spring-actuated knife inserts (6, 7), installed with

the possibility of interaction along wedge surfaces with leading 8 and driven 9 slides.

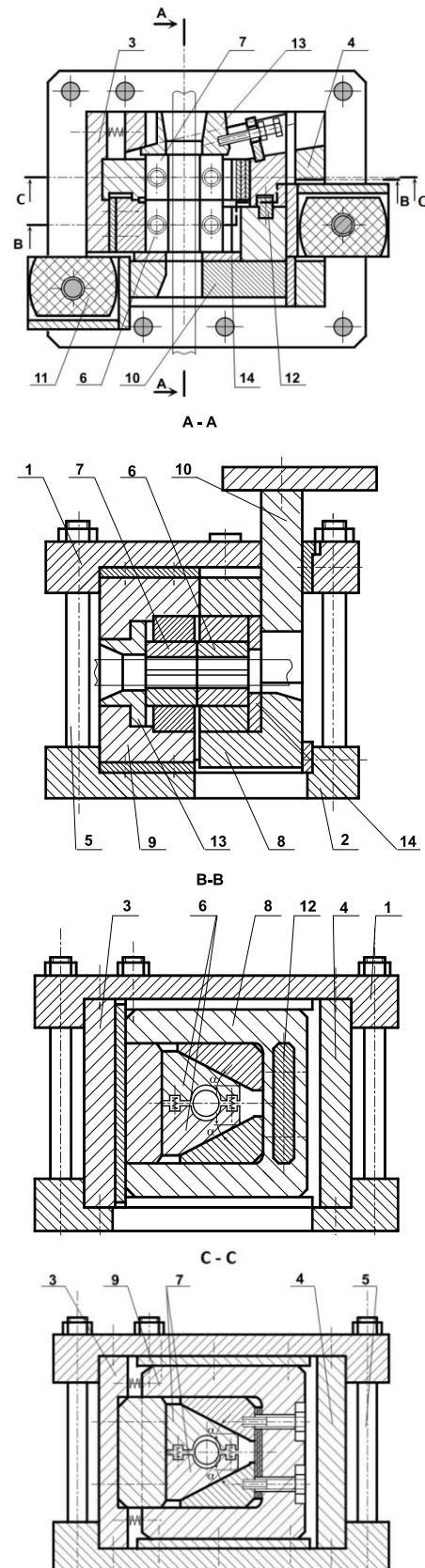

1, 2 – support plates; 3, 4 – cross plates; 5 – pins; 6,7 – knife inserts; 8 – leading slide; 9 – driven slide; 10 – pressing wedge; 11 – buffer; 12 – dowel; 13 – wedge; 14 – shutter

Figure 1. A stamp of the basic design for rolled stock cutting by shear with a differentiated clamp

The leading slide 8 interacts along the wedge surface with the pressing wedge 10 and is spring-actuated by a buffer 11, and the driven slide 9 is installed in the body in guideways orienting its movement only in the horizontal direction. In this case, the slides (8, 9) are interconnected by means of connector 12, which provides a joint horizontal displacement of the slides (8, 9) in the direction of the knife inserts (6, 7) and the vertical displacement of the leading slide against the driven one 9. With an increase in the pressing force, the cross-clamp force of the rolled stock increases, and when the vertical component of the force on wedge 10 exceeds the pre-compression force of the buffer 11, the leading slide 8 begins to move vertically, carrying out the final cutting of the workpiece. Axial clearance between the knife inserts (6, 7) is adjusted using wedge 13 and valve 14.

In the process of dividing in the vertical plane, a constant position of the rolled stock's axis is ensured. The force flow to the clamp through the rolled stock is excluded. The magnitude of the clamping force of the rolled stock is regulated by changing the pre-tightening force of the buffer. The stamp body is in the form of two support (1, 2) and two cross plates (3, 4), connected using pins 5 in such a way that the cross plates (3, 4) are installed along the edges in the support plates (1, 2), which makes it possible to increase the stamp rigidity significantly and to compensate for the expansion forces and twisting moments that arise during the cutting rolled stock. The slides (8, 9) in the form of rectangular closed-shaped plates with samples for the knife inserts (6, 7) provide high rigidity and strength of the slides under conditions of cyclic stresses. This increases the quality of the cut workpieces and the reliability of the stamp operation.

Compensation for the possible out-of-roundness of rolled stock, its bending along the length, and errors in the manufacture of the stamp parts are provided. As compared to the known designs, in the proposed stamp, the cross dimensions and weight are reduced on average by 25% and the height of the open stamp space – by 10%. The location of the knife inserts (6, 7) between wedge 13 and valve 14 allows for regrinding and replacing the knife inserts without disassembling the stamp.

2.1 FE Simulation of the forces and stress distribution

The simulation process of cutting rolled stock according to the scheme of incompletely closed cutting with a differentiated clamp was carried out using the specialized software *DEFORM 3D* [17-23]. The simulation was conducted for the rolled stock with a diameter of $d = 28$ mm and a length of $l = 75 \pm 0.5$ mm from steel 37Cr4 (ISO). To simulate the cutting process, the following parameters were set: knife movement speed – 0.65 m/s; rolled stock temperature – 20°C; material model – elastic-plastic (Normalized C&L); a number of elements – 300 000 pieces; Siebel friction – 0.35. The simulation results are shown in Fig. 2.

The calculated maximum force of the rolled stock cutting was $F_p = 265$ kN, corresponding to the stroke of the upper knife $h = 7.2$ mm.

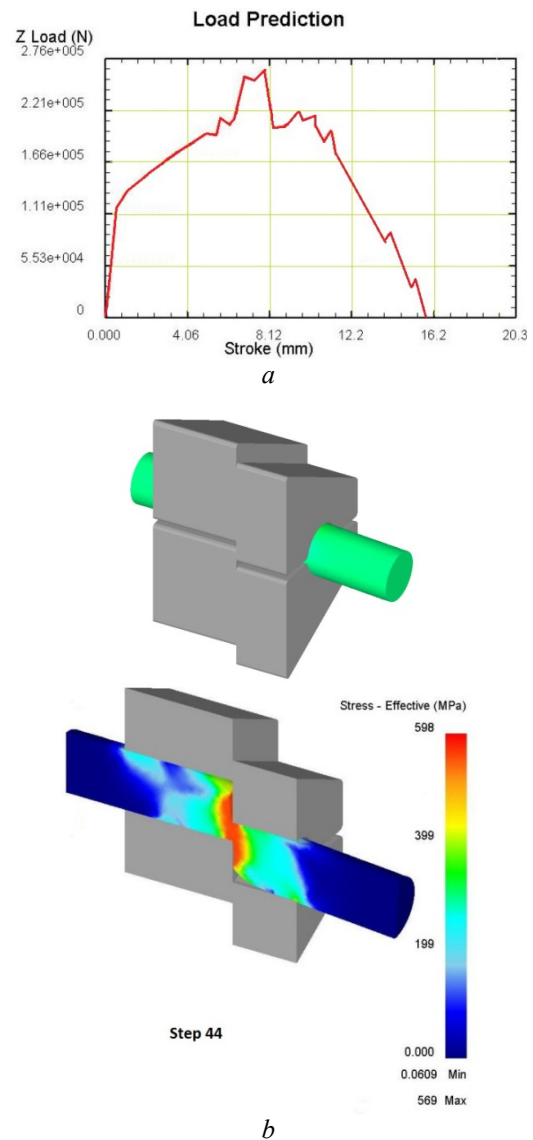

Figure 2. Cutting force vs. the stroke of the knife (a) and the distribution of stresses along the cross-section of rolled stock from steel 37Cr4 (b)

2.2 Analytical model of the forces acting on the stamp parts

A limitation of modeling in the *DEFORM 3D* software package is the impossibility of realizing the complex movement of the stamp parts: slides and knives. Therefore, using the calculated maximum cutting force, a force calculation of the proposed design stamp was carried out (Fig. 3). The purpose of the calculation is the selection of rational geometric dimensions for the main parts of the stamp and the calculation of the required press force.

1. Equations of the leading and driven slides equilibrium (see Fig. 3, a):

$$\begin{aligned}
 \sum F_{xi} &= 0; \\
 (F'_{tp1} + F'_{tp1}) \cdot \cos \alpha + (N_1 + N'_1) \cdot \sin \alpha - \\
 - N_2 \cdot \cos \beta + F_{tp2} \cdot \sin \beta + F_{pr} + R_1 &= 0; \\
 \sum F_{yi} &= 0; \\
 (N_1 - N'_1) \cdot \cos \alpha + (F'_{tr1} - F_{tr1}) \cdot \sin \alpha - \\
 - N_2 \cdot \sin \beta - F_{tr2} \cdot \cos \beta + R_b - G_1 &= 0;
 \end{aligned} \tag{1}$$

where F_{tpi} , N_i – frictional forces, and normal pressure on the contact surfaces of the stamp parts;

R_i – spring force;

R_b – force from the buffer;

G_i – the weight of a part;

α , β – angles of force transmission to clamp and cut rolled stock.

2. Equilibrium equations of knife inserts for elements:

a) equilibrium equation of the upper half-bushing (see Fig. 3, b):

$$\begin{aligned} \sum F_{yi} = 0: \\ F_p + \frac{1}{2} \cdot F_3 - N_1 \cdot \cos \alpha + \\ F_{tp1} \cdot \sin \alpha + F_{tp5} + R_3 - G_3 = 0 \end{aligned} \quad (2)$$

where F_p – maximum force of cutting of rolled stock by shear;

F_3 – clamp force of rolled stock;

b) equilibrium equation of the lower half-bushing (see Fig. 3, b):

$$\begin{aligned} \sum F_{yi} = 0: \\ -\frac{1}{2} \cdot F_3 - N_1' \cdot \cos \alpha - F_{tp1}' \cdot \sin \alpha + \\ + F_{tp5} - R_3 - G_3 = 0 \end{aligned} \quad (3)$$

3. Equilibrium equation of the push wedge (see Fig. 3, c):

$$\begin{aligned} \sum F_{yi} = 0: \\ F_{tp2} \cdot \cos \beta + F_{tp4} + N_2 \sin \beta - F_{pr} + R_2 - G_2 \end{aligned} \quad (4)$$

where F_{pr} – required press force.

Joint consideration of equations (1-4) gives a system of equations for calculating the forces acting in the stamp:

$$\begin{aligned} N_1 &= \frac{F_p - 1/2 \cdot F_3 - R_3 + G_3}{2 \cdot \mu \cdot \sin \alpha - \cos \alpha} \\ N_1' &= \frac{1/2 \cdot F_3 + R_3 + G_3}{\cos \alpha} \\ N_2 &= \frac{-N_1 \cdot \sin \alpha \cdot (1 + \mu^2)}{2 \cdot \mu \cdot \sin \beta + \cos \beta \cdot (\mu^2 - 1)} \times \\ &\times \frac{-N_1' \cdot (2 \cdot \mu \cdot \cos \alpha + \sin \alpha \cdot (1 - \mu^2)) - R_2 - \mu \cdot G_1}{2 \cdot \mu \cdot \sin \beta + \cos \beta \cdot (\mu^2 - 1)} \\ R_b &= N_2 \cdot (\sin \beta + \mu \cdot \cos \beta) - (N_1 - N_1') \times \\ &\times (\cos \alpha - \mu \cdot \sin \alpha) + G_1 \\ F_{pr} &= N_2 \cdot (2 \cdot \mu \cdot \cos \beta + \sin \beta) + R_2 - G_2 \end{aligned} \quad (5)$$

where μ – sliding friction coefficient.

For calculations, were used the forces of the springs, the dimensions, and the weight of the main parts of the stamp: $R_1 = 300N$; $R_2 = 1200N$; $R_3 = 400N$; $G_1 = 300N$; $G_2 = 80N$; $G_3 = 20N$. To ensure the high quality of the cut workpieces, it was believed that $F_3 = 1.5 \cdot F_p$.

The calculation results are shown in Fig. 4-6.

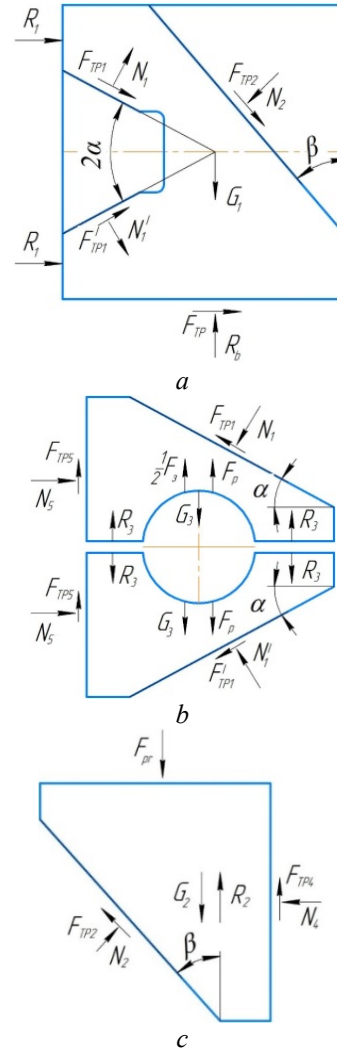

Figure 3. Forces acting on the main parts of the stamp

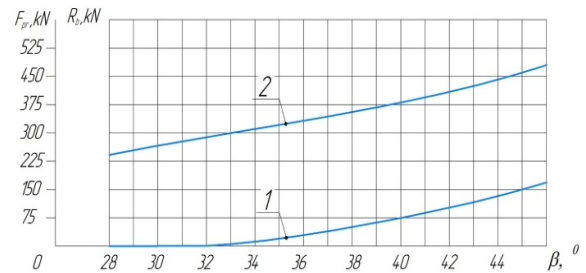

Figure 4. The buffer force (1) and the required press force (2) vs. angle of force transmission to the clamp and the cutting β at $\mu = 0.05$; $\alpha = 27^\circ$.

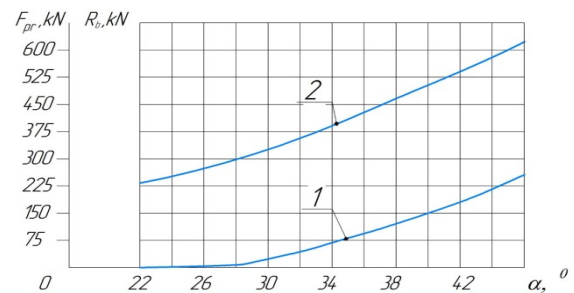

Figure 5. Buffer force (1) and the required press force (2) vs. angle of force transmission to the clamp and the cutting α at $\mu = 0.05$; $\alpha = 33^\circ$.

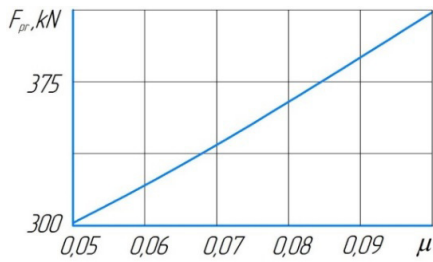

Figure 6. Required press force vs. friction coefficient at $\alpha = 27^\circ$, $\beta = 33^\circ$

The analysis of the obtained dependencies $R_a = f(\alpha)$ and $R_b = f(\beta)$ shows that at the angles of force transmission to the clamp and cutting rolled stock: $\alpha = 27^\circ$, $\beta = 33^\circ$ the force from the buffer has a minimum value $R_b \approx 10 \text{ kN}$ with the required press force $F_{pr} \approx 300 \text{ kN}$. Reducing the angle β is beyond the purpose due to a significant increase in the vertical stroke of the press, which predetermines the large overall dimensions of the stamp. In this case, the force R_b 's minimum value determines the buffer's minimum overall dimensions. To reduce the required press force F_{pr} (see Fig. 6), it is necessary to reduce the sliding friction coefficient by using antifriction materials on the contact surfaces and ensuring good lubrication conditions.

3. VERIFICATION OF OBTAINED RESULTS

The calculation results are confirmed by experimental studies conducted under factory conditions. According to the developed recommendations, a stamp with a differentiated clamp was designed and manufactured (Fig. 7).

DS 250/800 «Pels» crank press model of 2.5 MN power was used to cut the rolled stock. The rolled stock from steel 37Cr4 with mechanical characteristics: offset yield strength $\sigma_{0.2} = 324 \text{ MPa}$; tensile strength $\sigma_B = 588 \text{ MPa}$; relative elongation $\delta = 14\%$; relative reduction $\psi = 50\%$; hardness 168 HB are divided into workpieces with dimensions: $d = 28 \text{ mm}$, $l = 75 \pm 0.5 \text{ mm}$.

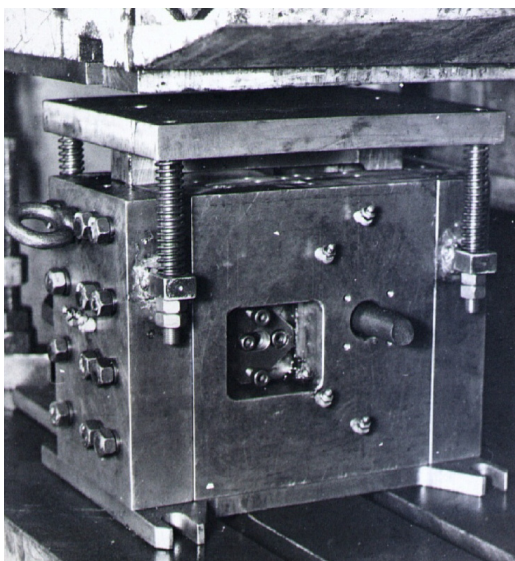

Figure 7. Photo of the stamp with the differentiated clamp of the rolled stock

Fig. 8 shows an experimental setup for measurement of force acting on press slide:

1 – Resistance strain gauges (half bridge, 200 Ohm), 2 – High-speed external I/O module (L-Card E-440), 3 – standard cable USB, 4 – PC with driving software for ADC (L-CARD).

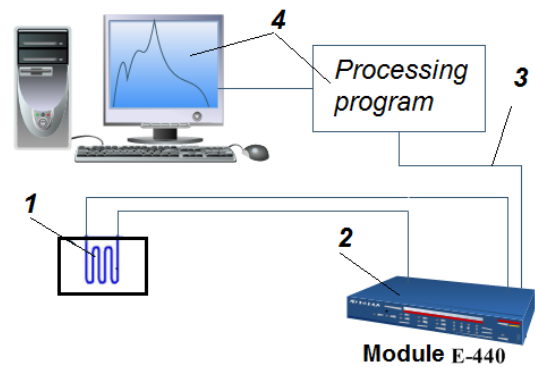

Figure 8. Installation for the acquisition of the force acting on press slide

The dependence of the force on the press slide from the slide stroke $F_{pr} = f(h)$ is shown in Fig. 9.

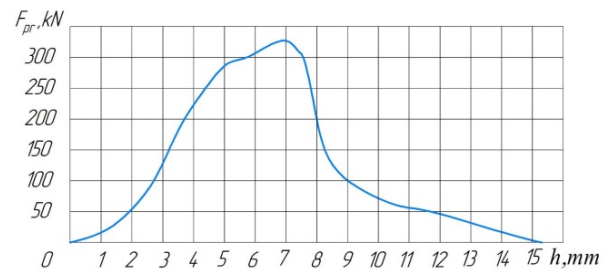
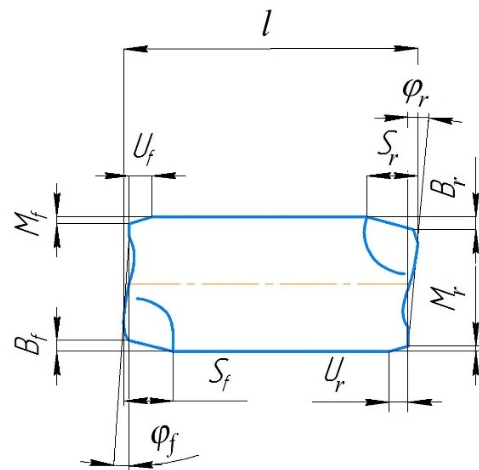

Figure 9. Force on the press slide vs. slide stroke during the cutting of rolled stock from 37Cr4 steel in a stamp with the differentiated clamp

Acceptance tests showed the operational integrity of a design.

The geometric accuracy of the cut workpieces was measured according to the scheme shown in Fig. 10.



φ – the angle of workpiece's end; M , U – cross and longitudinal dimensions of the tightening; B , S – cross and longitudinal dimensions of the knife marks; f , r – indexes indicating the front and rear ends

Figure 10. Basic parameters for evaluating the workpieces shape deviation

The results of the conducted measurements of the relative average values for the geometric shape distortions of the workpieces obtained by cutting in the stamp of the new design are presented in Table 1.

Table 1. Parameters of geometric accuracy of cut workpieces

Workpiece material	Degree of distortion									
	φ^0		$u = \frac{U}{d}$		$s = \frac{S}{d}$		$m = M/d$		$b = \frac{B}{d}$	
	φ_f	φ_r	U_f	U_r	S_f	S_r	M_f	M_r	B_f	B_r
Steel 37Cr4	0,5 0	0,55	0,35	0,35	0	0	0,03	0,04	0	0

Figure 11 shows photographs of workpieces made of 37Cr4 steel cut in the stamp with the differentiated clamp.

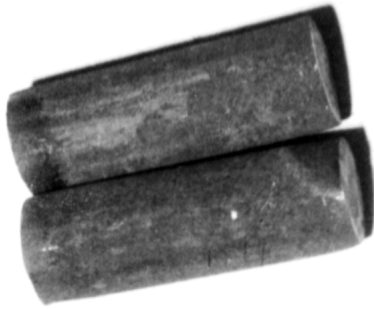

Figure 11. Workpieces of 37Cr4 steel cut in the stamp of new design

4. DISCUSSION OF OBTAINED RESULTS

A new stamp design with a differentiated clamp of rolled stock has been developed. According to their technical and economic indicators, these stamps equal modern samples of similar punch tools. The design of the stamp ensures its sufficiently high rigidity and relatively small overall dimensions. At the same time, in the process of cutting in the vertical plane, a constant position of the rolled stock's axis is ensured. The force transfer to the clamp through the rolling is excluded.

Based on the analysis of the mathematical model of a stamp with a differentiated clamp, the effective angles of force transfer to the clamp and the rolled stock between the stamp parts have been established. Analysis of the obtained dependencies $R_a = f(\alpha)$ and $R_b = f(\beta)$ has shown that at the angles of force transfer to the clamp and the cutting of the rolled stock: $\alpha = 27^\circ$; $\beta = 33^\circ$, the force from the buffer has the minimum value $R_b \approx 10 \text{ kN}$ with the required press force $F_{pr} \approx 300 \text{ kN}$. Reducing the angle is beyond the purpose due to a significant increase in the vertical stroke of the press, which predetermines the large overall dimensions of the stamp. In this case, the minimum value of the force R_b determines the minimum overall dimensions of the buffer. To reduce the required press force s , it is necessary to reduce the sliding friction coefficient by using antifriction materials on the contact surfaces and ensuring good lubrication conditions.

The results of the conducted experiments confirm the adequacy of the mathematical model. The value of the force on the slide of the press obtained experimentally is 10% more than the theoretical one. This is because it is necessary to more accurately take into account the value of the friction coefficient and its dependency on relative velocities on the contact surfaces of the stamp parts.

Recommendations for designing stamps with the differentiated clamp of rolled stocks were formulated based on a theoretical analysis, experimental investigations, and experience exploitation of such stamps. These results are summarized in Table 2 and are illustrated with corresponding structural diagrams. The corresponding references to the design of the stamp are represented by the recommendation number (see Tab. 2) in Fig. 12.

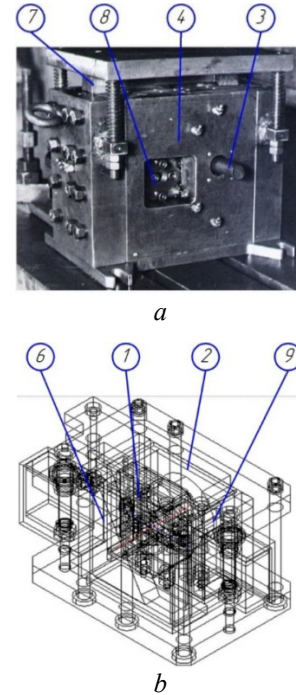
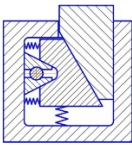
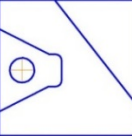
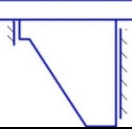
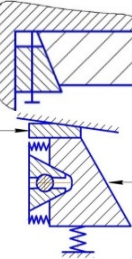
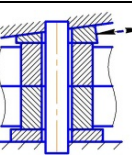

Figure 12. Photograph (a) and 3D model of the stamp with a differentiated clamp (b)

Table 2. Recommendations for the design of stamps with the differentiated clamp of rolled stocks

Recommendation	Design scheme
1	2
1. It is necessary to provide the differentiated clamp of rolled stocks on both sides of the separation plane. The force of the transverse clamp of rolled stocks is selected from the condition $F_3/F_p \geq 1$. This force is increased with decreasing of ratio $(\sigma_B - \sigma_{0,2})/\sigma_B$	
2. The separation of the workpieces should be produced in the vertical plane to reduce losses related to contact friction.	
3. The rolled stocks axis should be fixed during clamp and cutting to simplify the feed of the rolled stocks.	
4. The body of the stamp must be box-shaped to compensate for expansion forces and torsional moments of forces: in the form of transverse plates covering the longitudinal plates with the formation of locks; with grooves in base plates;	

Recommendation	Design scheme
1	2
<ul style="list-style-type: none"> with fastening to the bottom base plate. 	
5. The leading and driven sliders with knife inserts must be placed within a closed frame to increase a rigidity	
6. The power parts of the stamp must be made of a closed form with stiffeners to ensure strength under the action of cyclic stresses	
7. The pressure wedge must be made with developed guides to compensate for resulting bending moments	
8. The design of the stamp must provide the adjustment of errors in the manufacture of stamp parts and the possible ovality of rolled stocks: <ul style="list-style-type: none"> horizontal; vertical 	
9. For ease of assembly, disassembly, and adjustment, the knife inserts should be located between the shutter and the wedge	

5. CONCLUSIONS

1. According to their technical and economic indicators, the new design stamps are not inferior to modern samples of similar stamp equipment. Compared to known designs, the transverse dimensions and weight are reduced by an average of 25%, and the open stamp space height by 10%. The stamp has high rigidity. In the process of separation in the vertical plane, a constant position of the rolled axis is ensured. The transmission of force to the clamp through the rolled stocks is excluded.

2. Based on the mathematical model analysis of a stamp with a differentiated clamp, the effective angles of force transfer to the clamp and the rolled segment between the stamp parts are established. At the angles of force transfer to the clamp and cutting of the rolled stocks: $\alpha = 27^\circ$; $\beta = 33^\circ$, the force from the buffer side has a minimum value $R_b \approx 10 \text{ kN}$ at the required press force $F_{pr} \approx 300 \text{ kN}$. Reducing the angle β is impractical due to a significant increase in the vertical stroke of the press, which predetermines the large overall dimensions of the stamp. In this case, the force R_b 's minimum value determines the buffer's minimum overall dimensions. To reduce the required force of the press F_{pr} , it is necessary to reduce the coefficient of sliding friction by using antifriction materials on the contact surfaces and ensuring good lubrication conditions.

3. The adequacy of the mathematical model has been confirmed experimentally. The 10% discrepancy is due

to the fact that for theoretical calculations, the rolled material was selected from the *Deform 3D* steel base, which is as close as possible in mechanical properties to 37Cr4 steel but still differs from it. Besides, it is necessary to more accurately take into account the value of the friction coefficient and its dependence on the relative velocities on the contact surfaces of the stamp parts.

4. The results of the stamp introduction at the Odessa Production Association «Stroigidravlika» show that: the stamps are efficient and reliable in operation; the quality of cut blanks corresponds to the quality indicators of blanks cut on modern, similar equipment. In this case, it is necessary to ensure a zero gap between the knife's inserts.

5. The recommendations for designing stamps with the differentiated clamp of rolled stocks have been developed.

REFERENCES

- [1] Lisunets, N. L.: Usage of physical and mathematical simulation for improvement of the processes of metal shear cutting, *CIS Iron and Steel Review*, No 17, pp. 34–38, 2019.
- [2] Lisunets, N. L.: Improving the efficiency of the processes of workpieces manufacture from rolled metal via shift cutting based on simulation, *Chernye Metally*, No (6), pp. 31-35, 2018.
- [3] Huang, G., Wang, J., Hsu, M., et al.: Application of mold trough design to blanking technology, *The International Journal of Advanced Manufacturing Technology*, No 88, pp. 1025-1034, 2017.
- [4] Karnaukh, S. G., Markov, O. E., Aliieva, L. I., et al.: Designing and researching of the equipment for cutting by breaking of rolled stock, *International Journal of Advanced Manufacturing Technology*, No 109, pp. 2457-2464, 2020. doi: 10.1007/s00170-020-05824-7
- [5] Karnaukh, S., Karnaukh, D.: Research of the influence of deformation speed on energy and power adjectives of the process of three-point cold bend breaking and on alignment integrity of raw parts, *Metallurgical and Mining Industry*, Vol. 3, No 7, pp. 107-114, 2011.
- [6] Karnaukh, S. G.: Studying the process of static-dynamic loading of a preform according to the scheme of three-point breaking by bending in press-hammers, *Kuznechno-Shtampovochnoe Proizvodstvo (Obrabotka Metallov Davleniem)*, No 2, pp. 8-12, 2001.
- [7] Luo, C., Chen, Z., Zhou, K., et al.: A novel method to significantly decrease the die roll during fine-blanking process with verification by simulation and experiments, *Journal of Materials Processing Tech.*, No 250, pp. 254-260, 2017.
- [8] Hu, X. H., Choi, K. S., Sun, X., et al.: Edge fracture prediction of traditional and advanced trimming processes for AA6111-T4 sheets, *Journal of Manufacturing Science and Engineering*, No 136, 11 pages, 2014.

- [9] Zhao, P. J. et al.: Experimental and numerical analysis of micromechanical damage for DP600 steel in fine-blanking process, *Journal of Materials Processing Technology*, No 236, pp. 16-25, 2016.
- [10] Zagirnyak, M. et al.: A search for technologies implementing a high fighting efficiency of the multilayered elements of military equipment, *Eastern-European Journal of Enterprise Technologies*, No 6 (1-102), pp. 33-40, 2019.
- [11] Gao, M., Wang, Q., Li, L., et al.: Comprehensive energy-saving method for sheet metal forming, *The International Journal of Advanced Manufacturing Technology*, No 104, pp.2273–2285, 2019.
- [12] Xiao, Y., Zhang, H., Jiang, Z.: An approach for blank dimension design considering energy consumption, *The International Journal of Advanced Manufacturing Technology*, No 87, pp. 1229–1235, 2016.
- [13] Chehab, A. G., Naggar, E. I.: Design of efficient base isolation for hammers and presses, *Soil Dynamics and Earthquake Engineering*, No 23, pp. 127-141, 2003.
- [14] Won, C., Lee, W., Lee, H., et al.: Effect of two-stage press blanking on edge stretchability with third-generation advanced high-strength steels, *The International Journal of Advanced Manufacturing Technology*, No 110, pp. 13-27, 2020.
- [15] Krininger, M. et al.: On the opportunities of problem- and process-adapted shear cutting simulations for effective process design, *Procedia Engineering*, No 207, pp.1570–1575, 2017.
- [16] Hrudkina, N., Aliieva, L., Abhari, P., et. Al.: Investigating the process of shrinkage depression formation at the combined radialbackward extrusion of parts with a flange, *Eastern-European Journal of Enterprise Technologies*, No. 5(1-101), 49-57, 2019. doi:10.15587/1729-4061.2019.1792 32.
- [17] Pimenov, D.Y., Guzeev, V.I.: Mathematical model of plowing forces to account for flank wear using FME modeling for orthogonal cutting scheme, *International Journal of Advanced Manufacturing Technology*, No 89, pp. 3149–3159, 2017. doi.org/10.1007/s00170-016-9216-x
- [18] Y. Liu, L. Hua, H. Mao, W. Feng: Finite element simulation of effect of part shape on forming quality in fine-blanking process, *Procedia Engineering*, No 81, pp. 1108-1113, 2014.
- [19] Wu, L. et al.: 3D FEM simulation of chip breakage in turning AISI1045 with complicate-grooved insert, *International Journal of Advanced Manufacturing Technology*, No. 108, pp. 1331–1341, 2020. doi.org/10.1007/s00170-020-05460-1.
- [20] Jomartov, A., Tuleshov, A., Kumatova, M.: Dynamic model of a crank press in the process of braking, *Robotics and Mechatronics*, Springer International Publishing Cham, pp. 141-150, 2020.
- [21] Telegin, V. V., Kozlov, A. M., Sakalo, V. I.: Solid modeling and dynamic analysis of mechanisms of press-forging machines, *Procedia Engineering*, No 206, pp. 1258-1263, 2017.
- [22] Liu, Y., Hua, L., Mao, H., et al.: Finite element simulation of effect of part shape on forming quality in fine-blanking process, *Procedia Engineering*, No 81, pp. 1108-1113, 2014.
- [23] Kim, S., Tsuruoka, K., Yamamoto, T.: Effect of forming speed in precision forging process evaluated using CAE technology and high performance servo-press machine, *Procedia Engineering*, No 81 (2014), pp. 2415-2420, 2014.
- [24] Krobath, M. et al.: Tensile stresses in fine blanking tools and their relevance to tool fracture behavior, *International Journal of Machine Tools and Manufacture*, No. 126, pp. 44-50, 2018.
- [25] Markov, O., Gerasimenko, O., Khvashchynskiy, A., et al.: Modeling the technological process of pipe forging without a mandrel, *Eastern-European Journal of Enterprise Technologies*, No. 3(1-99), 42-48, 2019. doi:10.15587/1729-4061.2019.167077
- [26] Pat. 25552 A (Ukraine), MKI V 23 D23/00. Stamp for driving rolled products with a differentiated clamp / Roganov, L. L., Tarasov, O.F., Karnaukh, S. G. – Applied. 03.06.1997, Publ. 30.10.1998. – 4 p. (*in Russian*).

NOMENCLATURE

F_{fpi}	frictional forces on the contact surfaces of the stamp parts: leading, driven crawlers – knife inserts; leading crawler – pressing wedge
F'_{fpi}	
R_i	spring force
R_b	the force from the buffer
G_i	weight of a part
α, β	angles of force transmission to clamp and cutting of rolled stock
F_p	the maximum force of cutting by shear
F_3	clamp force of rolled stock
μ	sliding friction coefficient
$\sigma_{0,2}$	offset yield strength
σ_B	tensile strength
δ	relative elongation
ψ	relative reduction
HB	hardness
d	diameter of sample
L	specimen length
φ	the angle of the workpiece face
M_f	front cross and longitudinal dimensions of tightening and dints
U_f	
B_f	cross and longitudinal dimensions of the knife marks (see Figure 10)
S_f	
M_r	rear cross and longitudinal dimensions of tightening and dints
U_r	
B_r	cross and longitudinal dimensions of the knife marks (see Figure 10)
S_r	

РАЗВОЈ И ИСТРАЖИВАЊЕ ПЕЧАТА ЗА СЕЧЕЊЕ ВАЉАНОГ МАТЕРИЈАЛА СА ДИФЕРЕНЦИРАНОМ СТЕГОМ

С.Г. Карнаух, О. Марков, А.А. Шапалов, К.В. Зубенко

Рад има за циљ развој и истраживање печата са диференцираним стезаљкама ваљаног материјала за сечење смицањем. Развијен је нови дизајн печата са диференцираним стезаљкама ваљаног материјала. По својим техничким и економским показатељима ови печати задовољавају или превазилазе савремене узорке сличних алата за бушење. Истовремено, у процесу вертикалног сечења, обезбеђује се константан положај осе ваљаног материјала. Пренос силе на стезаљку кроз ваљани материјал је искључен. Дизајн печата обезбеђује његову довољно високу крутост и релативно мале укупне димензије. На основу анализе математичког модела жига са диференцираним стезаљком, утврђени су ефективни углови преноса силе на стегу и пресецања ваљаног материјала између делова штанца. Добијени модел је коришћен за оптимизацију углова преноса силе на стезаљку и сечење ваљаног материјала, поштујући

силу са стране одбојника и минималну потребну силу притиска. Истовремено, вертикални ход покретних делова је смањен, укупне димензије печата су смањене, а тампон такође има минималну величину. Да би се смањила потребна сила пресе, потребно је смањити вредност коефицијента фрикционог клизања коришћењем антифрикционих материјала на контактним површинама и обезбеђивањем добрих услова подмазивања. Резултати спроведених експеримената потврђују адекватност математичког модела. Вредност потребне силе на клизач преса доступна из експеримената је нешто већа од вредности добијених развијеним аналитичким моделом. Резултати имплементације печата показују да су: марке ефикасне и поуздане у експлоатацији; квалитет одсечених обрадака одговара показатељима квалитета обрадака сечених на сличној савременој опреми.